

Theme : 3

Support by Power Assist Suit

Group:13

National Institute of Technology, Wakayama College

Kotaro Shimada

○ Ryo Hashimoto

Reiya Hiasa

○ Ami Morikawa

Naoaki Tsuda

Background

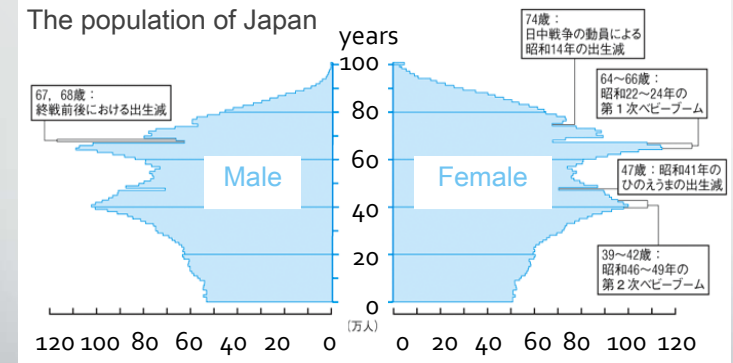

Source: <http://www.soumu.go.jp>

▶ Declining birth rates

▶ Population aging

Background

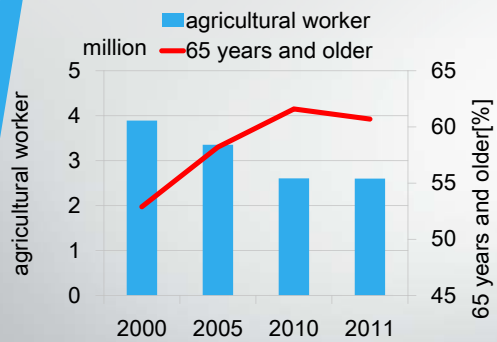

Aging of agricultural workers

Source: <http://www.soumu.go.jp>

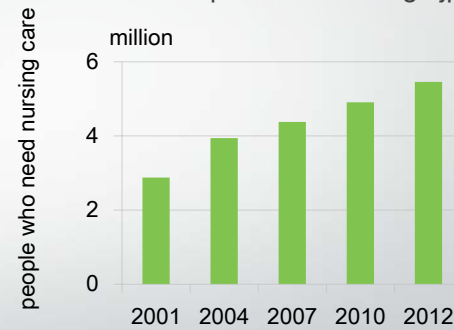

Increase of the care burden

Support by robot is expected.

Background

Robots for agriculture works



THOUZER produced by Doog



Strawberry picking robot produced by Utsunomiya Univ.

✕ Movement on rough ground
Employment problem

Background

Robots for agriculture works



Muscle Suit
produced
by INNOPHYS

Power assist suit

- Movement on rough ground
- Employment problem

Background



KAI-R produced by
Yamanashi Univ.



Active plaster
produced by Mie Univ.

Source : <http://www.robot.mach.mie-u.ac.jp/html/research.html>

Introduction in a wide range of fields is expected.

Outline

- (1) Power assist suit outline
- (2) For luggage handling operation auxiliary
- (3) For rehabilitation
- (4) Conclusion & Graduation research

Power assist suit

Another name : Powered exoskeleton
Robot for assisting human works

Types of power assist suits

- For luggage handling operation auxiliary
- For harvest work auxiliary
- For rehabilitation

For luggage handling operation auxiliary



AWN-03 produced by activelink

Features

- ▶Assisting force is switched automatically.
- ▶To put on and take off within 30 seconds is possible.

Specifications

Assisting force	15kgf
Weight	ca.6kg
Drive time	8 hours

For luggage handling operation auxiliary



Muscle Suit produced by INNOPHYS

Source : <http://innophys.jp/product.html>

Features

- ▶McKibben artificial muscles
- ▶High-powered

Specifications

Assisting force	30kgf
Weight	ca.5.5kg+1.5kg
Drive time	16 hours ※Air supply is necessary

McKibben artificial muscles

... rubber tube is covered with sleeve

Mechanism

Pressurizing the tube

Radial direction : expansion
Axial direction : contraction

Contractile force

Advantage: High-power, Light, Cheap
Disadvantage: Air supply is necessary

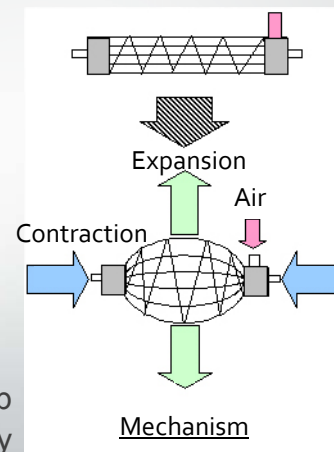

Mechanism

For luggage handling operation auxiliary



Muscle Suit produced by INNOPHYS

Features

- ▶Without power source
- ▶High-powered & Light-weight

Specifications

Assisting force	25kgf
Weight	ca.4kg
Drive time	Infinite

Source : <http://activelink.co.jp/doc/151.html>

Pneumatic artificial muscles

Mechanism

User crouches using the weight of the upper part of body.



The air pressure energy is charged.



Charged energy is used for next motion.



A worker can lift the luggage easily.

Muscle Suit Movie



Effectiveness of the Power assist suits

- ▶ Luggage handling works became easy.
- ▶ Participation of female became possible.
- ▶ Workload decreased about 70%



For rehabilitation



Features

- ▶ HAL is automatically controlled based on BES (Bio-Electric signals)
- ▶ Possible to do rehabilitations while wearing HAL.

Specifications

Weight	ca.1.5kg
Drive time	120 mins

HAL produced by CYBERDYNE

Source : <http://www.cyberdyne.jp/products/SingleJoint.html>

BES (Bio-electric signals)

BES is a weak electric signals that occurs when the muscles move.

Types of BES

- ▶ **Electromyogram**
- ▶ Electroencephalogram

Electromyogram

Flow chart of Electromyogram

Signal is sent from the brain when moving the body.



Muscle contraction



Very weak electrical signal leaks to the skin surface.

We call this signal "**Electromyogram**"

Block diagram of HAL

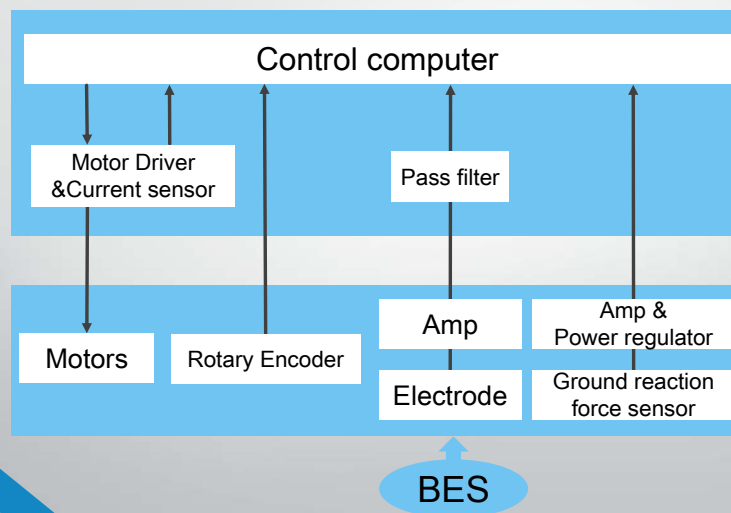

Market trend

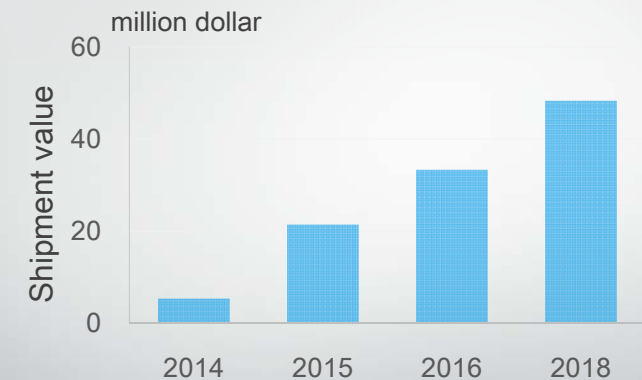

Market of power assist suit is **expanding** rapidly.

Source : <https://www.yano.co.jp/press/press.php/001452>

Market trend

Corporate customers	Personal customers
Many	Few
Market is expanding. ↓ Price will be reduced	
Many	Many

Conclusions

- ▶ Assist robot let a agriculture works and nursing works easy.
- ▶ Possible to maintain employment and the worker's motivation.
- ▶ In the future, the market will expand.

Finally

- ▶ Our graduation thesis are about robots for assisting crutch users and calligraphy trainee.
- ▶ Experiences in this IRH2015 must be helpful for doing our researches.
- ▶ We appreciate everyone who supported us.



Calligraphy training



Crutch walk training

Thank you for your attention

Background

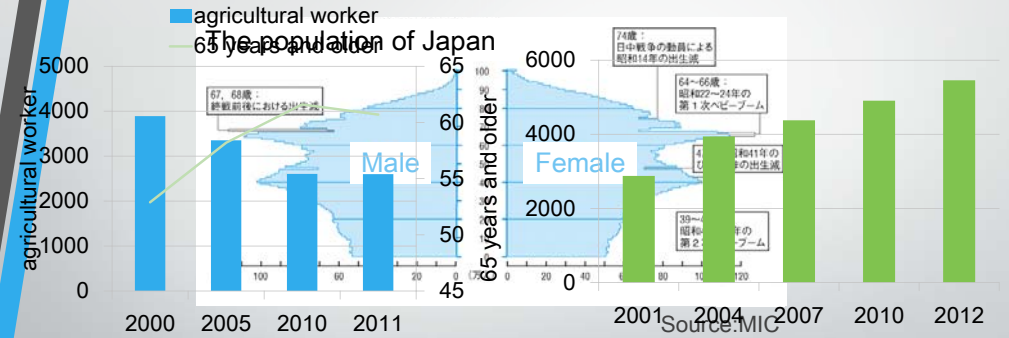

Aging of agricultural workers, Declining birth rates, Increase of the care burden

Support by robot is expected.

Background

Agricultural support robot



THOUZER produced by Utsunomiya Univ.



Power assist suit



strawberry picking robot produced by Utsunomiya Univ.

Background

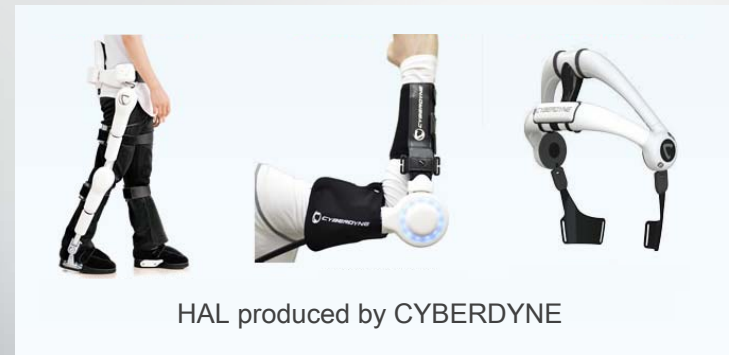

HAL produced by CYBERDYNE

It is expected in a wide range of fields.

Pneumatic artificial muscles

McKibben Artificial Muscles

... Covering the rubber tube in the sleeve

Pressure the tube



Radial direction : expansion
Axial direction : contraction



Contractile force

Advantage: High-power&Light&Cheap

Disadvantage: Air supply is necessary

